

# EXT5100 Special Parts 専用部品

EXT5100 Series 差動上下送りシリンダベッド型オーバーロックミシン  
Variable top feed cylinder bed overedgers

## Parts Catalog

From the library of: Diamond Needle Corp



**PEGASUS®**

## パーツカタログの見方

- このパーツカタログは、2004年2月製造中のEXT5100シリーズミシンの専用部品のみを次の要領で編集しています。  
※ 専用部品以外の部品は、EX5100シリーズと同じ部品を使用しています。EX5100シリーズパーツブックをご覧ください。(Cat. No. 97290)
- 2～23頁には部品を機構別に収録し、左頁が部品の分解図、右頁がパーツリストになっています。また、部品分解図に付されている番号は、パーツリストのREF.NO. (参照番号)を示しています。
- パーツリストの部品番号の表記がXXXXXXの部品は、特定の形式(サブクラス)にのみ使用されているゲージパーツ部品で、形式によって変わります。形式ごとの部品番号はゲージパーツ表(24～25頁)に一括して記載しています。
- 巻末には部品番号インデックスを記載し、部品番号だけで、その図解・名称などが容易に引き出せます。
- 部品を御注文いただく時は、部品番号を明示してください。なお、このパーツカタログの記載事項は改良により、予告なく変更されることがありますので、あらかじめご了承ください。

## INTRODUCTION

- This parts catalog contains only special parts for the EXT5100 Series that are in the making as of February, 2004.  
※ Since common parts are used between the EX5100 Series, refer to the EX5100 Series parts book (Cat. No. 97290) for parts except special ones.
- The components of EXT5100 series are arranged according to the mechanism on pages 2-23. The illustrations are on left pages and the part numbers on right pages. The illustrated part and its part number are assigned the same reference number.
- "XXXXXX" indicates gauge part numbers which vary depending on subclasses. Please refer to the gauge part list (pages 24-25).
- The index of part numbers are listed at the back of this book for quick reference.
- To place an order for any part, please specify the part number. Note that the contents of this book are subject to change for improvement without prior notice.

### 掲載機種 (Models inserted)

#### EXT5100 Series

EXT5104-02/233N

EXT5114-03/333N

EXT5104-04/433

EXT5104-04/433N

EXT5114-04/433

EXT5114-04/433N

EXT5105-12/223N

EXT5104T-02/233N

EXT5104-02/233N

EXT5104-02/233N

EXT5104-02/233N

EXT5104-02/233N

EXT5104-02/233N

## 目次

	頁
上送り機構 (1) .....	2 ~ 3
上送り機構 (2) .....	4 ~ 5
上送り機構 (3) .....	6 ~ 7
ベッド, カバー機構 .....	8 ~ 9
針振り, 上下メス機構 .....	10 ~ 11
押工機構 .....	12 ~ 13
給油機構 .....	14 ~ 15
専用部品 (1) EXT5104-02,04,EXT5114-03,04,EXT5105-12 .....	16 ~ 17
専用部品 (2) EXT5104T-02 .....	18 ~ 19
専用部品 (3) EXT5104T-02 .....	20 ~ 21
裾引き用アタッチメント .....	22 ~ 23
ゲージパーツ表 .....	24 ~ 25
糸通し図一覧 .....	26
インデックス .....	27

## TABLE OF CONTENTS

	page
TOP FEED MECHANISM(1) .....	2 ~ 3
TOP FEED MECHANISM(2) .....	4 ~ 5
TOP FEED MECHANISM(3) .....	6 ~ 7
MACHINE BED FRAME, COVER .....	8 ~ 9
NEEDLE DRIVE, KNIFE DRIVE MECHANISM .....	10 ~ 11
PRESSER FOOT MECHANISM .....	12 ~ 13
LUBRICATION MECHANISM .....	14 ~ 15
SPECIFIC PARTS(1) EXT5104-02,04,EXT5114-03,04,EXT5105-12 .....	16 ~ 17
SPECIFIC PARTS(2) EXT5104T-02 .....	18 ~ 19
SPECIFIC PARTS(3) EXT5104T-02 .....	20 ~ 21
ATTACHMENT FOR BLINDSTITCH HEMMING .....	22 ~ 23
GAUGE PARTS LIST .....	24 ~ 25
THREADING DIAGRAM .....	26
INDEX .....	27

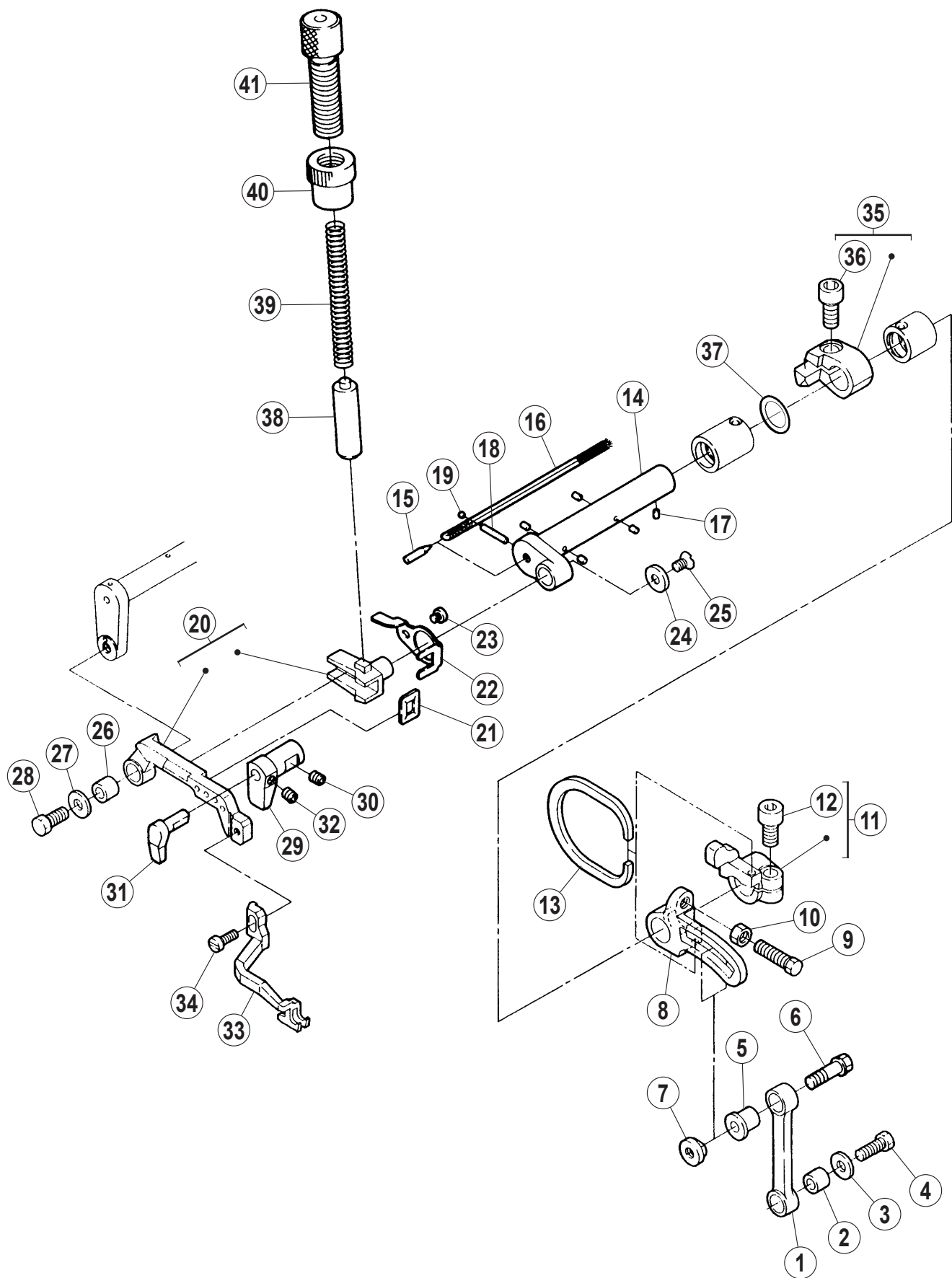

## 上送り機構 (1)

## TOP FEED MECHANISM(1)

REF.NO.	PART NO.	部品名称	DESCRIPTION	QT.
1	2765340	リンク	LINK	1
2	2405420	ブッシュ	BUSHING	1
3	2400390	座金	WASHER	1
4	0070560	六角ボルト /M5X13	BOLT	1
5	2765350	ブッシュ	BUSHING	1
6	0072330	六角ボルト /M5X17	BOLT	1
7	2765260	ナット	NUT	1
8	2765330	クランク	CRANK	1
9	0072060	六角ボルト /M6X22	BOLT	1
10	0072070	六角ナット /M6	NUT	1
11	276536-920	カラー	COLLAR	1
12	0045330	六角穴ボルト /M6X12	BOLT	1
13	2765380	板バネ	FLAT SPRING	1
14	276527A0	クランク	CRANKSHAFT	1
15	2403680	ピン	PIN	1
16	2021760	給油紐	OIL WICK	1
17	2073580	フェルト	FELT	5
18	179320-050	フェルト	FELT	1
19	2401480	球	BALL	1
20	276528-910	上送り台 (組)	TOP FEED BAR ASSY.	1
21	2765390	油切り	OIL SEAL	1
22	2765400	油切り案内	GUIDE/FEED BAR SEAL	1
23	0070070	平小ネジ /M3X3	SCREW	1
24	2402940	座金	WASHER	1
25	0070440	皿小ネジ /M4X10	SCREW	1
26	2405420	ブッシュ	BUSHING	1
27	2400390	座金	WASHER	1
28	0070560	六角ボルト /M5X13	BOLT	1
29	2765310	上送り台案内	GUIDE/TOP FEED BAR	1
30	0045430	六角穴止ネジ /M4X4	SCREW	1
31	2765320	上送り台案内	GUIDE/TOP FEED BAR	1
32	0045430	六角穴止ネジ /M4X4	SCREW	1
33	XXXXXXX	上送り歯	TOP FEED DOG	1
34	0070140	平小ネジ /M3.5X10	SCREW	1
35	276520-920	カラー	COLLAR	1
36	0045340	六角穴ボルト /M6X14	BOLT	1
37	2082350	座金	WASHER	1
38	2740350	押工棒	PRESSER BAR	1
39	2402910	圧縮バネ	SPRING	1
40	2740370	ナット	NUT	1
41	2740360	調節ネジ	SCREW	1

From the library of: Diamond Needle Corp

● xxxxxx はゲージパーツです。  
部品番号は 24 ~ 25 頁のゲージパーツ表を  
参照してください。

● "xxxxxx" represents the gauge part.  
Please refer to the gauge part list (page 24-25)

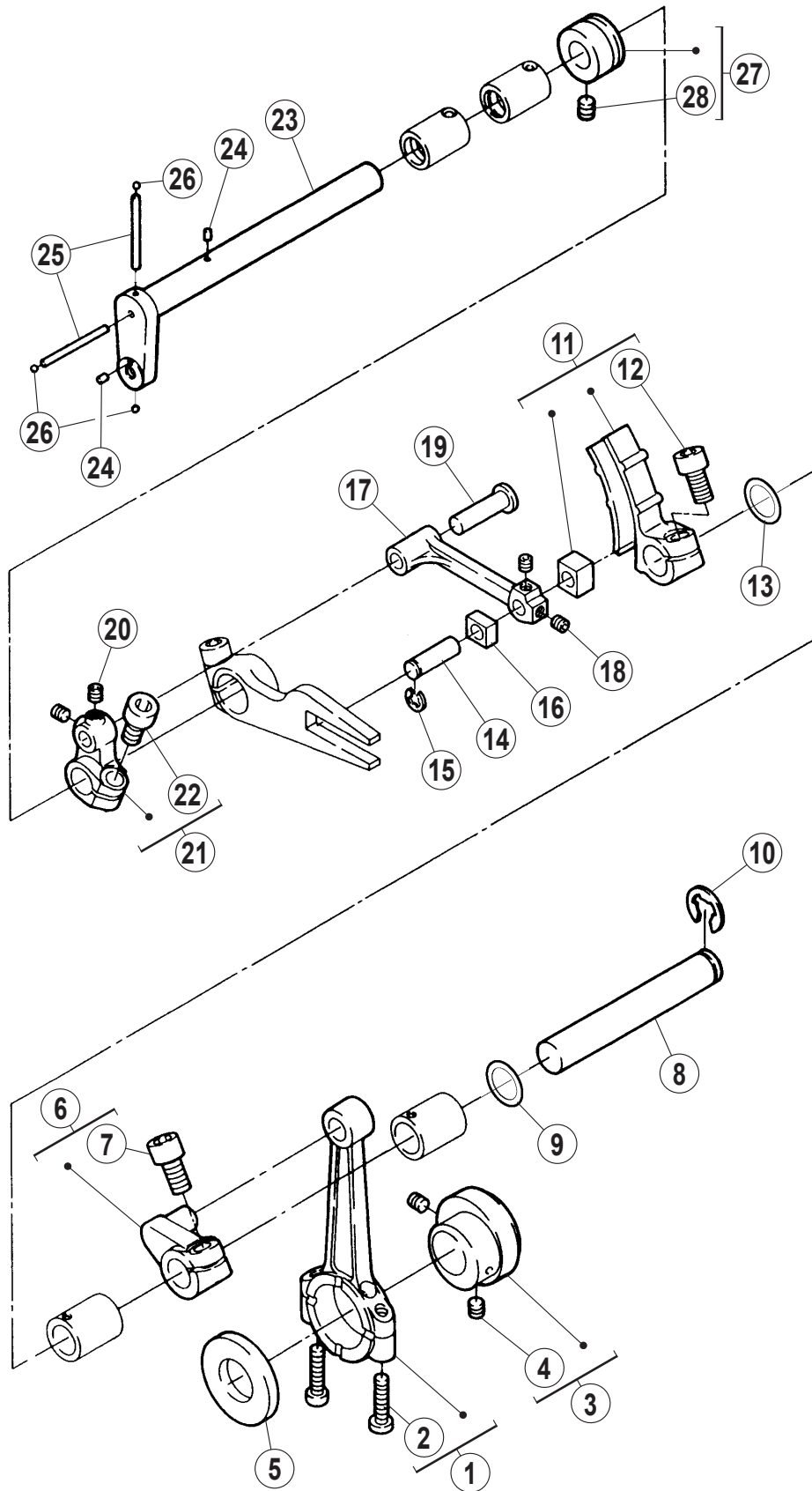

## 上送り機構 (2)

## TOP FEED MECHANISM(2)

REF.NO.	PART NO.	部品名称	DESCRIPTION	QT.
1	276501A920	ロッド	CONNECTION	1
2	007024A0	十字穴ナベ小ネジ /M4X18	SCREW	2
3	276566-920	エキセン	ECCENTRIC	1
4	0045140	六角穴止ネジ /M5X5	SCREW	2
5	2765670	座金	WASHER	1
6	276572-920	クランク	CRANK	1
7	0045330	六角穴ボルト /M6X12	BOLT	1
8	271003C0	軸	SHAFT	1
9	2082350	座金	WASHER	1
10	2025770	止メ輪	RING	1
11	276504-910	クランク (組)	CRANK ASSY.	1
12	0045330	六角穴ボルト /M6X12	BOLT	1
13	2082350	座金	WASHER	1
14	2765070	平行ピン	PIN	1
15	2016290	止メ輪	RING	1
16	2765080	角駒	BLOCK	1
17	2765090	リンク	LINK	1
18	0045430	六角穴止ネジ /M4X4	SCREW	2
19	2765100	ピン	PIN	1
20	0045430	六角穴止ネジ /M4X4	SCREW	2
21	276511-920	クランク	CRANK	1
22	0045330	六角穴ボルト /M6X12	BOLT	1
23	2765120	クランク軸	CRANKSHAFT	1
24	2073580	フェルト	FELT	2
25	2403510	フェルト	FELT	2
26	2401480	球	BALL	3
27	276537-920	カラー	COLLAR	1
28	0045140	六角穴止ネジ /M5X5	SCREW	1

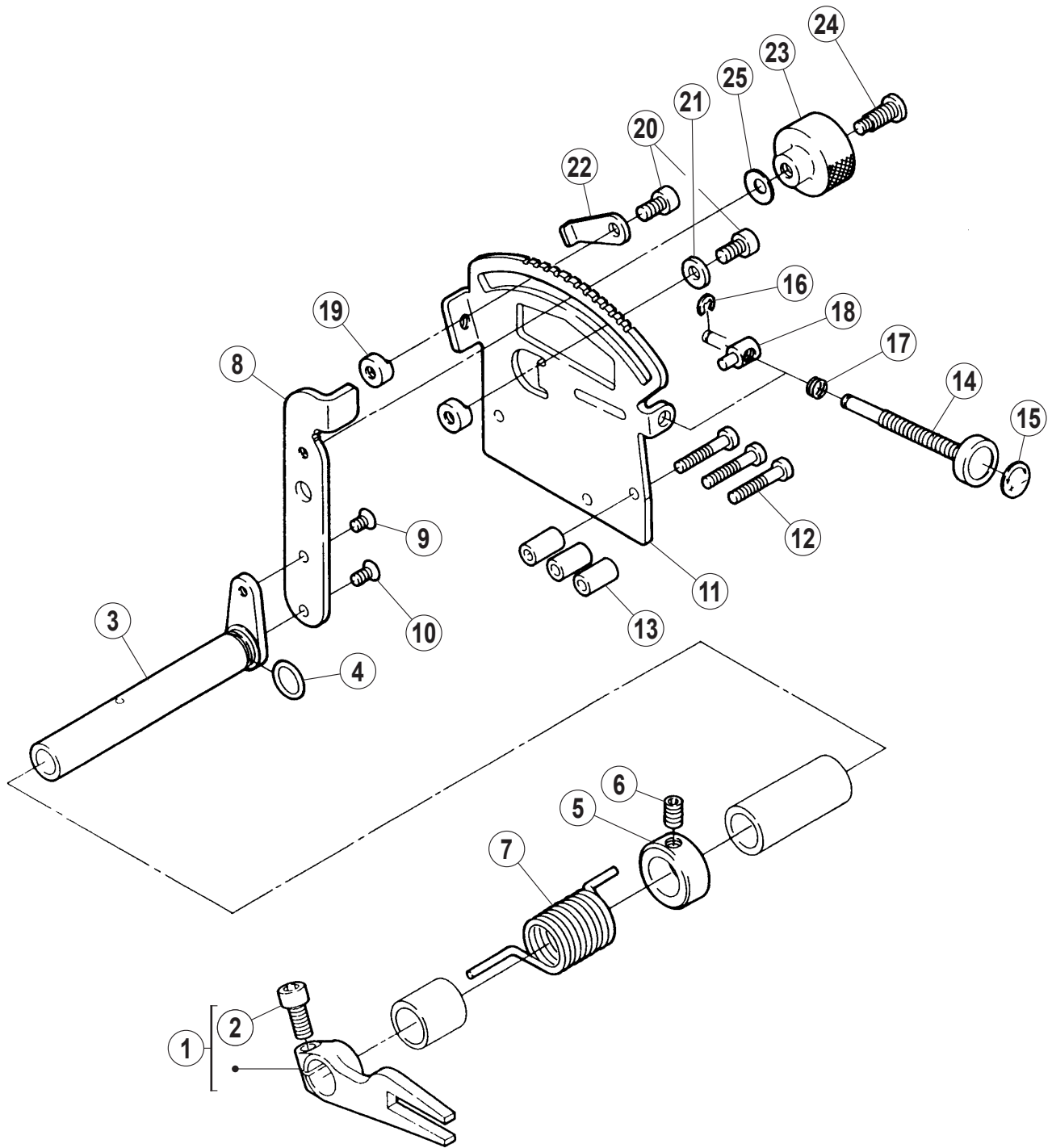



### 上送り機構 (3)

### TOP FEED MECHANISM(3)

REF.NO.	PART NO.	部品名称	DESCRIPTION	QT.
1	276513-920	レバー	LEVER	1
2	0045340	六角穴ボルト /M6X14	BOLT	1
3	276514A0	レバー軸	SHAFT	1
4	2010220	Oリング	O RING	1
5	2402960	カラー	COLLAR	1
6	0045210	六角穴止ネジ /M6X10	SCREW	1
7	2765730	ネジリバネ	SPRING	1
8	2765170	レバー	LEVER	1
9	0070770	皿小ネジ /M4X7	SCREW	1
10	0070440	皿小ネジ /M4X10	SCREW	1
11	2765180	調節板	BLADE GUIDE	1
12	0070260	平小ネジ /M4X25	SCREW	3
13	2403320	スペーサ	SPACER	3
14	272538A0	調節棒	ADJUSTING BAR	1
15	2403220	シール	SEAL	1
16	2005550	止メ輪	RING	1
17	2405590	圧縮バネ	SPRING	1
18	272539A0	段付ピン	PIN	1
19	179201-050	ナット	NUT	2
20	0045000	六角穴ボルト /M5X10	BOLT	2
21	2400420	座金	WASHER	1
22	2765240	ストッパ	STOPPER	1
23	2765190	ナット	NUT	1
24	0070590	段ネジ /M4.5	SCREW	1
25	2113010	皿バネ	SPRING	1

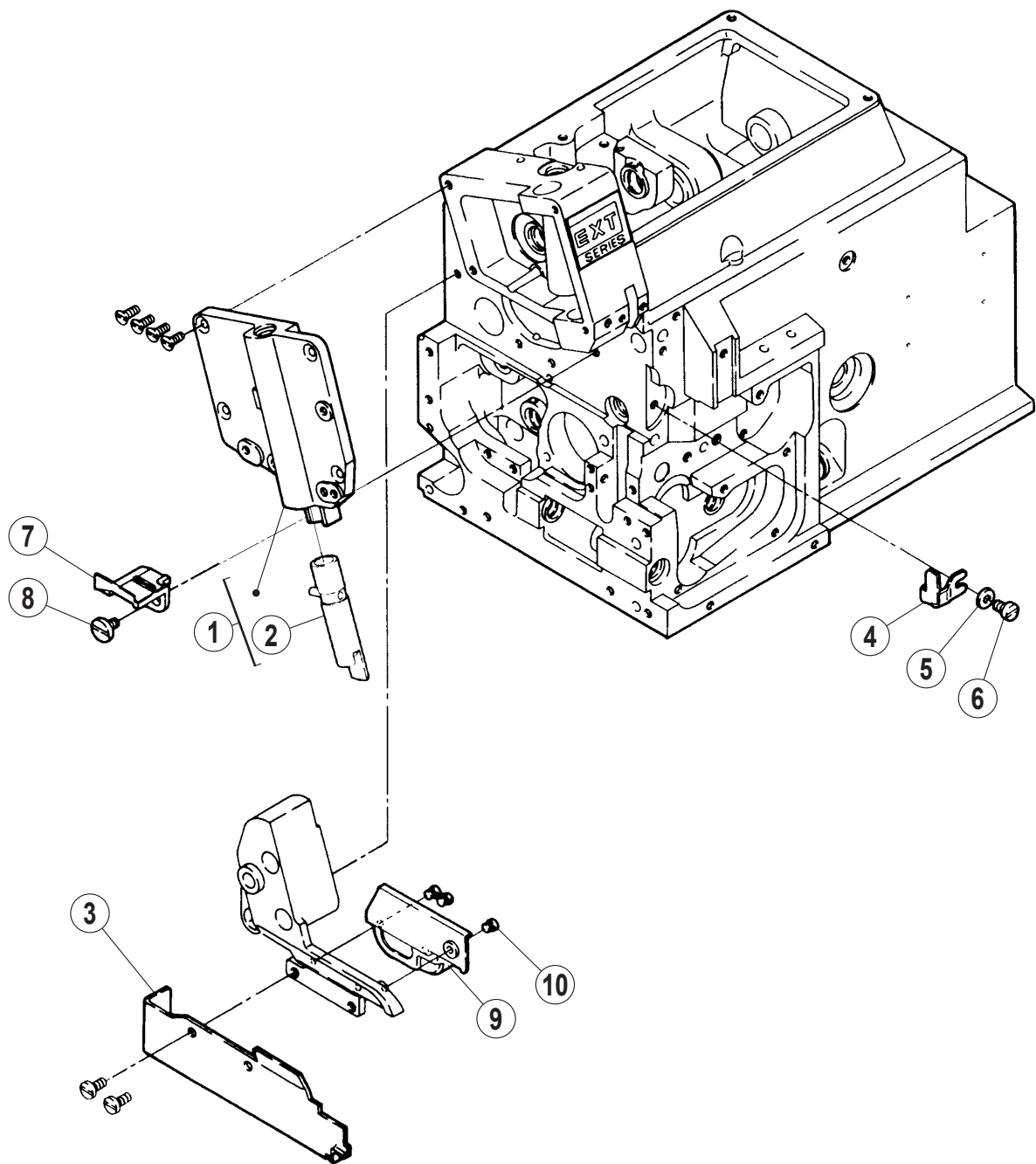

## ベッド, カバー機構

## MACHINE BED FRAME, COVER

REF.NO.	PART NO.	部品名称	DESCRIPTION	QT.
1	270083A9U0	側面カバー (組)	SIDE COVER ASSY.	1
2	274011-910	押工棒	PRESSER BAR	1
3	2701680	布案内	FABRIC GUIDE	1
4	2700810	カバー	COVER	1
5	2109300	皿バネ	SPRING	1
6	0071430	ナベ小ネジ /M4X5.5	SCREW	1
7	2700790	カバー	COVER	1
8	0070660	段ネジ /M4	SCREW	1
9	2700670	カバー	COVER	1
10	0071540	平小ネジ /M3X3.5	SCREW	3

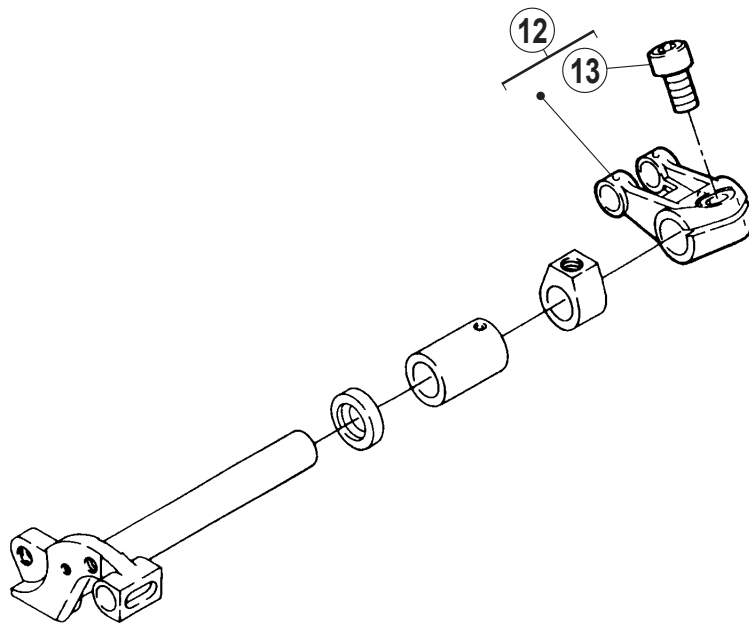
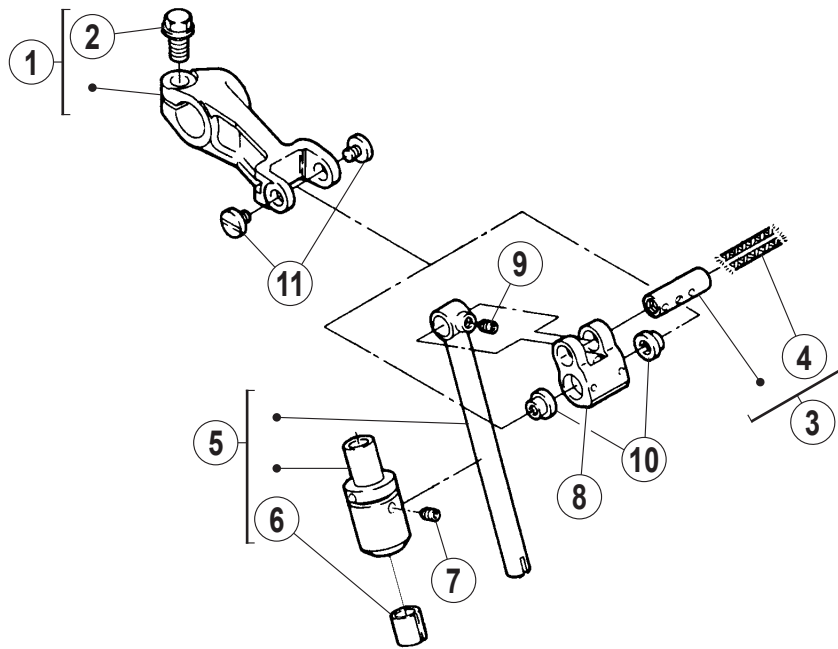

## 針振り, 上下メス機構

## NEEDLE DRIVE, KNIFE DRIVE MECHANISM

REF.NO.	PART NO.	部品名称	DESCRIPTION	QT.
1	271015-920	レバー	LEVER	1
2	0071500	六角ボルト /M6X12	BOLT	1
3	271023-910	軸 (組)	SHAFT ASSY.	1
4	2021760	給油紐	OIL WICK	2
5	271018C91Y0	針棒ブッシュ (組)	BUSHING ASSY.	1
6	179009-050	フェルト	FELT	1
7	0045820	六角穴止ネジ /M4X8	SCREW	1
8	2710160	リンク	LINK	1
9	0045450	六角穴止ネジ /M3X4	SCREW	1
10	2710170	段付ピン	PIN	2
11	0071850	平小ネジ /M3X4	SCREW	2
12	273001A920	クランク	CRANK	1
13	0045330	六角穴ボルト /M6X12	BOLT	1

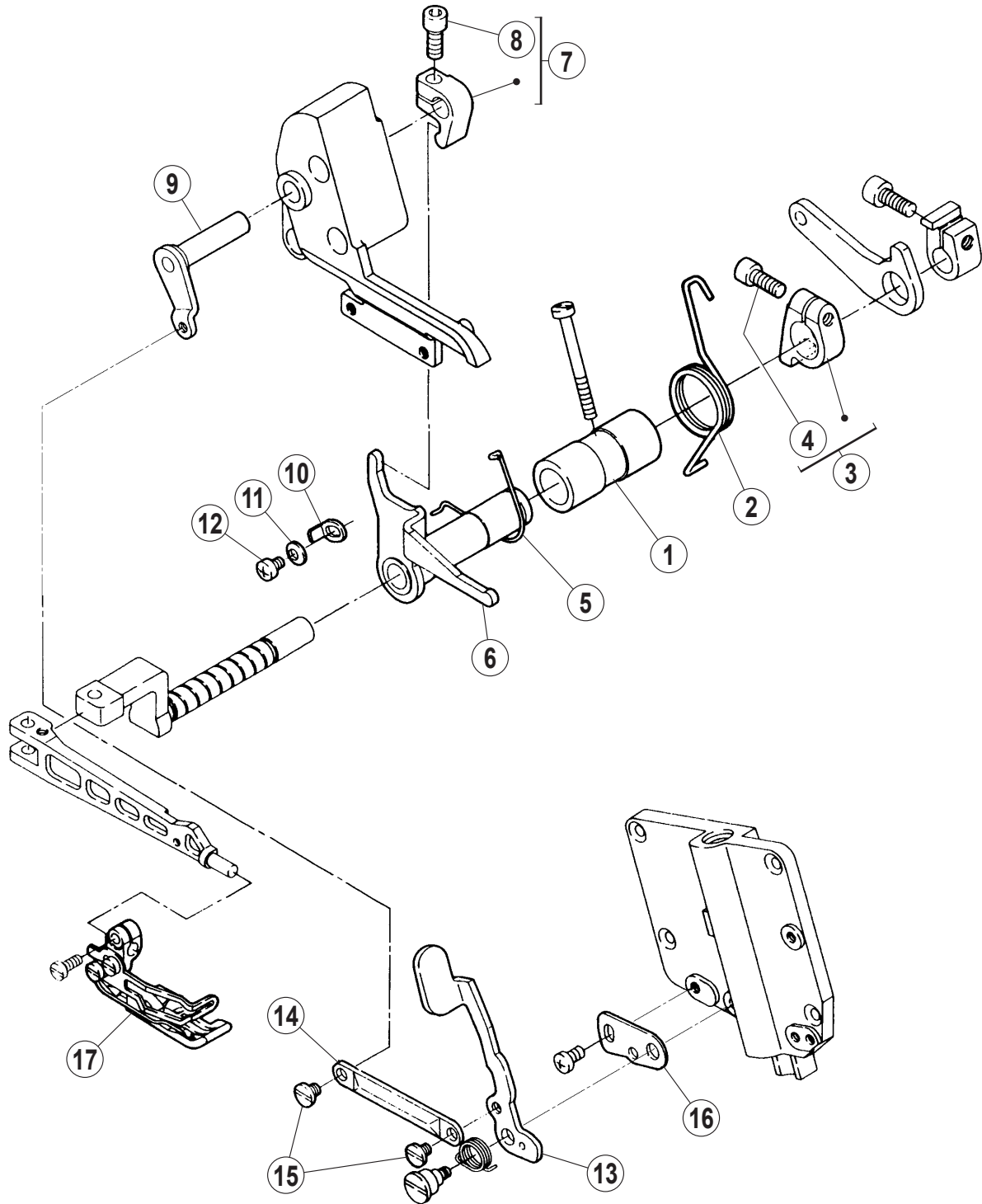

## 押工機構

## PRESSER FOOT MECHANISM

REF.NO.	PART NO.	部品名称	DESCRIPTION	QT.
1	2740440	ブッシュ	BUSHING	1
2	274043A0	ネジリバネ	SPRING	1
3	274042-920	カラー	COLLAR	1
4	0045010	六角穴ボルト /M5X14	BOLT	1
5	2740550	線細工バネ	SPRING	1
6	274045-910	レバー	LEVER	1
7	213218A920	レバー	LEVER	1
8	0045310	六角穴ボルト /M5X12	BOLT	1
9	274048-910	レバー	LEVER	1
10	2740540	ストッパ	STOPPER	1
11	2109300	皿バネ	SPRING	1
12	007018A0	十字穴ナベ小ネジ /M4X6	SCREW	1
13	2740390	レバー	LEVER	1
14	2740410	リンク	LINK	1
15	0071931	段ネジ /M4	SCREW	2
16	2740400	ストッパ	STOPPER	1
17	XXXXXX	押工 (組)	PRESSER FOOT ASSY.	1

● xxxxxx はゲージパーツです。  
部品番号は 24 ~ 25 頁のゲージパーツ表を  
参照してください。

● "xxxxxx" represents the gauge part.  
Please refer to the gauge part list (page 24-25)

EXT5100 Series

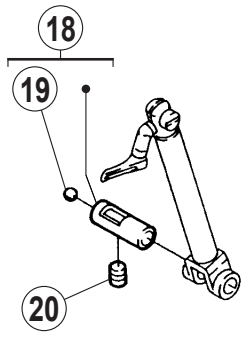

EXT5104T-02

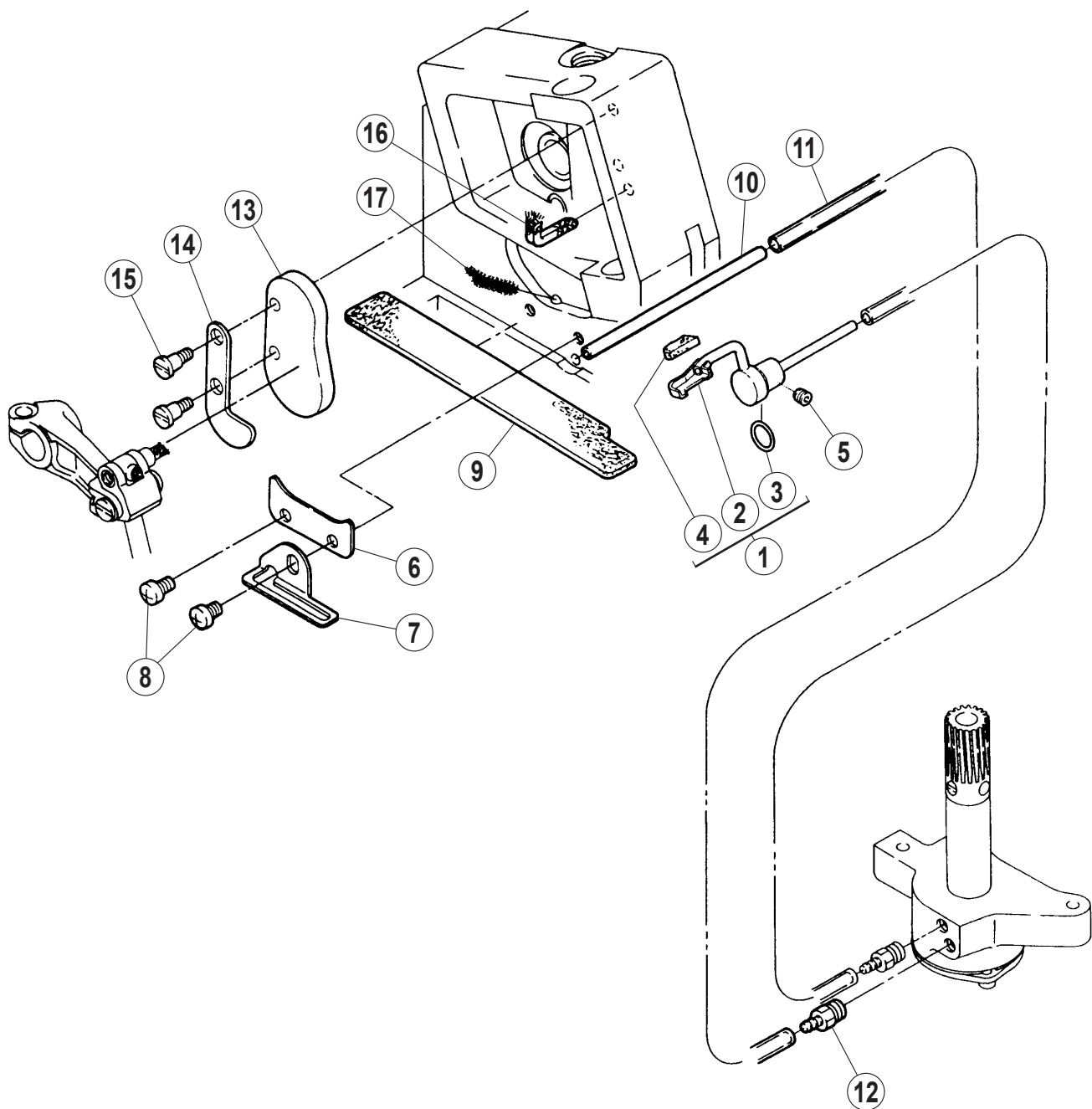
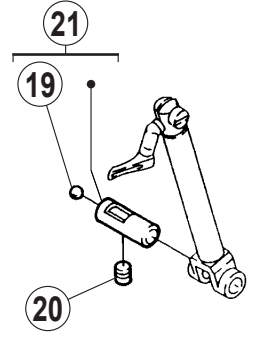



## 給油機構

## LUBRICATION MECHANISM

REF.NO.	PART NO.	部品名称	DESCRIPTION	QT.
1	274551A910	排油継手 (組)	JOINT ASSY.	1
2	274552A910	排油継手	JOINT	1
3	2041850	Oリング	O RING	1
4	2745560	フェルト	FELT	1
5	0045430	六角穴止ネジ /M4X4	SCREW	1
6	2745500	カバー	COVER	1
7	2745590	当金	SPACER	1
8	007018A0	十字穴ナベ小ネジ /M4X6	SCREW	2
9	2745490	フェルト	FELT	1
10	2103200	銅管	EXHAUST OIL DISTRIBUTOR	1
11	2403710	チューブ	TUBE	1
12	2745920	継手	JOINT	1
13	2745290	フェルト	FELT	1
14	2745300	カバー	COVER	1
15	0071920	段ネジ /M4	SCREW	2
16	2021760	給油紐	OIL WICK	1
17	2401520	モール	OIL WICK	1
18	274517B910	パイプ (組)	PIPE ASSY.	1
19	2400970	球	BALL	1
20	0045430	六角穴止ネジ /M4X4	SCREW	1
21	274593B910	パイプ (組)	PIPE ASSY.	1

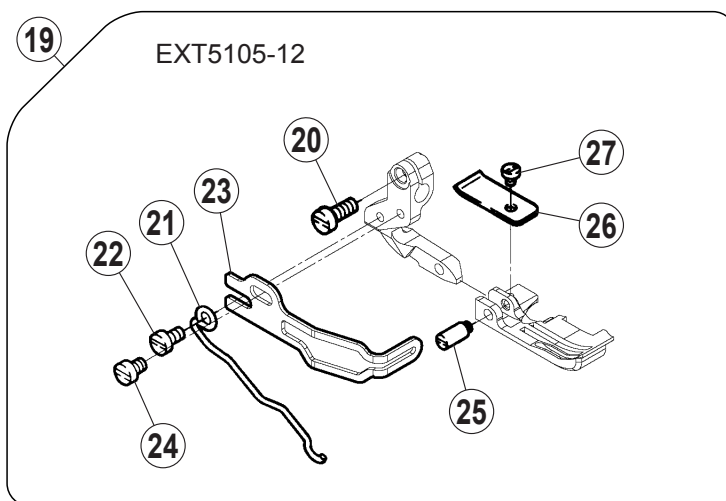
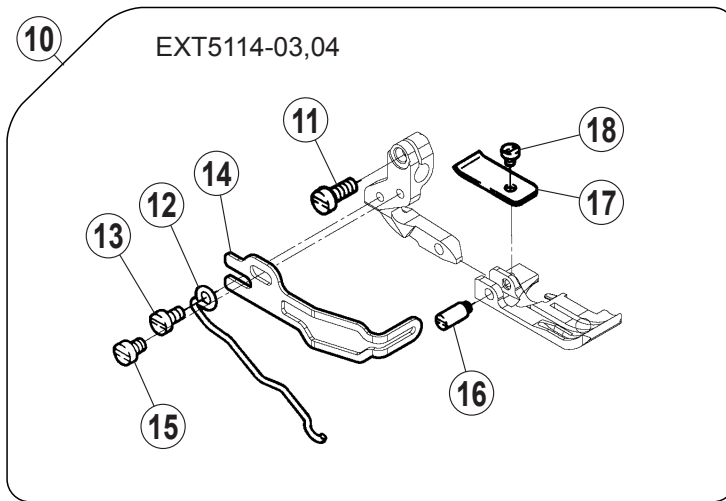
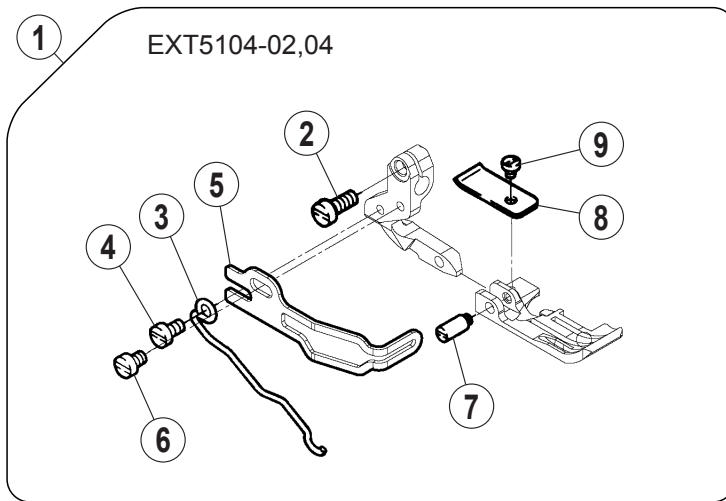

## 専用部品 (1)

## SPECIFIC PARTS(1)

REF.NO.	PART NO.	部品名称	DESCRIPTION	QT.
1	XXXXXX	押工 (組)	PRESSER FOOT ASSY.	1
2	0070130	平小ネジ /M3.5X8	SCREW	1
3	2740510	ネジリバネ	SPRING	1
4	0070100	平小ネジ /M3X6	SCREW	1
5	2741060	フィンガーガード	FINGER GUARD	1
6	0070090	平小ネジ /M3X5	SCREW	1
7	212059-B0	ピンネジ /C1	SCREW	1
8	2126680	押工補助板	PRESSER FOOT AUXILIARY PLATE	1
9	0050300	平ネジ /C1X2.3	SCREW	1
10	XXXXXX	押工 (組)	PRESSER FOOT ASSY.	1
11	0070130	平小ネジ /M3.5X8	SCREW	1
12	2740510	ネジリバネ	SPRING	1
13	0070100	平小ネジ /M3X6	SCREW	1
14	2741060	フィンガーガード	FINGER GUARD	1
15	0070090	平小ネジ /M3X5	SCREW	1
16	212059-B0	ピンネジ /C1	SCREW	1
17	2126680	押工補助板	PRESSER FOOT AUXILIARY PLATE	1
18	0050300	平ネジ /C1X2.3	SCREW	1
19	XXXXXX	押工 (組)	PRESSER FOOT ASSY.	1
20	0070130	平小ネジ /M3.5X8	SCREW	1
21	2740510	ネジリバネ	SPRING	1
22	0070100	平小ネジ /M3X6	SCREW	1
23	2741060	フィンガーガード	FINGER GUARD	1
24	0070090	平小ネジ /M3X5	SCREW	1
25	212059-B0	ピンネジ /C1	SCREW	1
26	2126680	押工補助板	PRESSER FOOT AUXILIARY PLATE	1
27	0050300	平ネジ /C1X2.3	SCREW	1

● xxxxxx はゲージパーツです。  
部品番号は 24 ~ 25 頁のゲージパーツ表を  
参照してください。

● "xxxxxx" represents the gauge part.  
Please refer to the gauge part list (page 24-25)

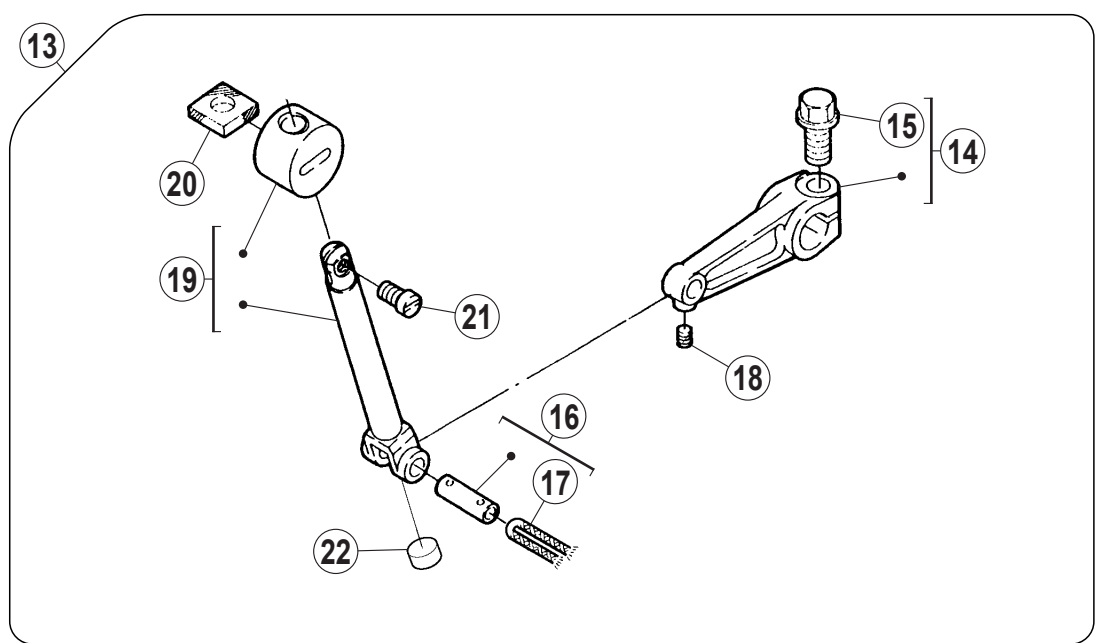
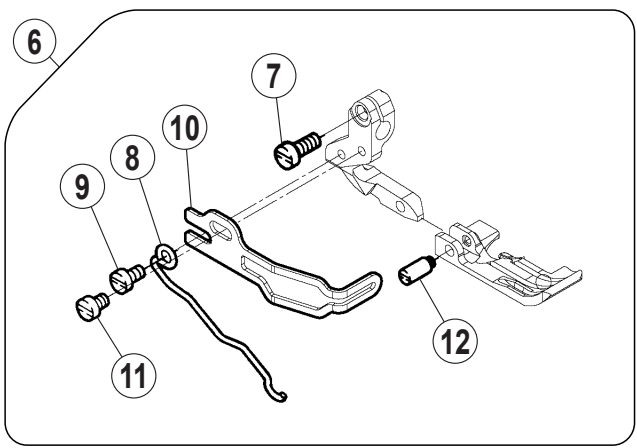
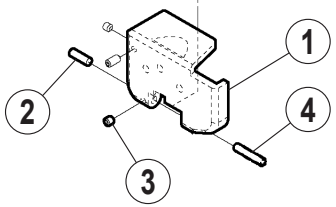
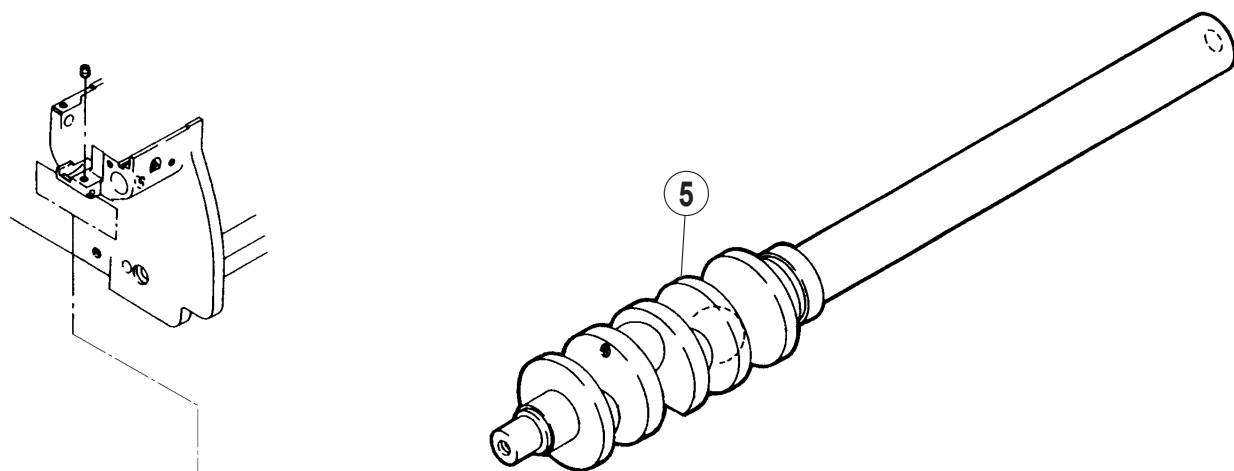

## 専用部品 (2)

## SPECIFIC PARTS(2)

REF.NO.	PART NO.	部品名称	DESCRIPTION	QT.
1	213062B0	横カバー	SIDE COVER	1
2	3065270	平行ピン	PIN	1
3	0045540	六角穴止ネジ /M3X3	SCREW	1
4	2402830	平行ピン	PIN	1
5	270522C0	クランク軸	CRANKSHAFT	1
6	XXXXXX	押エ (組)	PRESSER FOOT ASSY.	1
7	0070130	平小ネジ /M3.5X8	SCREW	1
8	2740510	ネジリバネ	SPRING	1
9	0070100	平小ネジ /M3X6	SCREW	1
10	2741060	フィンガーガード	FINGER GUARD	1
11	0070090	平小ネジ /M3X5	SCREW	1
12	212059-B0	ピンネジ /C1	SCREW	1
13	271544-91Y0	上ルーパー台セット	UPPER LOOPER HOLDER ASSY.	1
14	271542-920	レバー	LEVER	1
15	0071500	六角ボルト /M6X12	BOLT	1
16	2715460	平行ピン (組)	PIN ASSY.	1
17	2021760	給油紐	OIL WICK	1
18	0045450	六角穴止ネジ /M3X4	SCREW	1
19	271533B910	上ルーパー台 (組)	UPPER LOOPER HOLDER ASSY.	1
20	179130-050	フェルト	FELT	1
21	0070541	平小ネジ /M3.5X6.7	SCREW	1
22	2330350	フェルト	FELT	1

● xxxxxx はゲージパーツです。  
部品番号は 24 ~ 25 頁のゲージパーツ表を  
参照してください。

● "xxxxxx" represents the gauge part.  
Please refer to the gauge part list (page 24-25)

EXT5104T-02

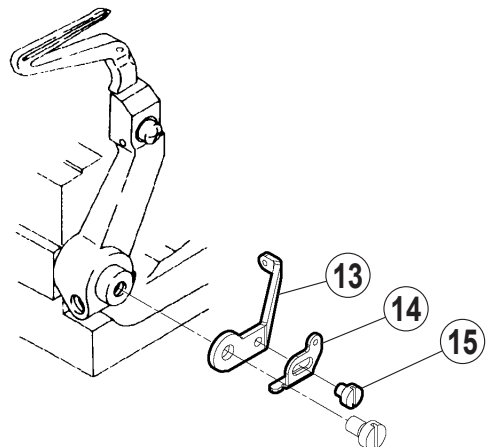
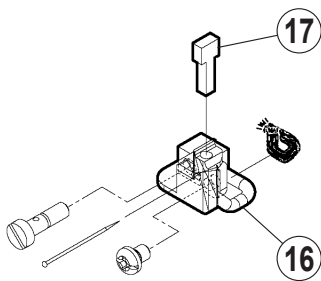
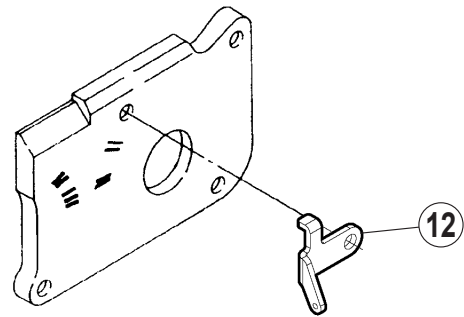
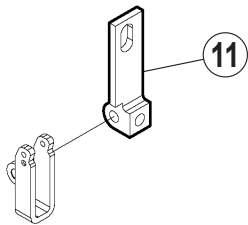
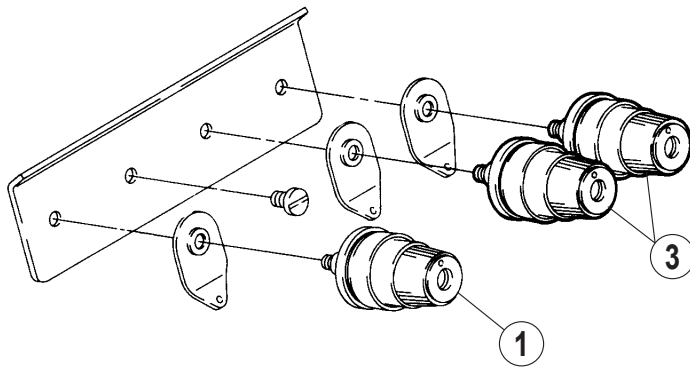
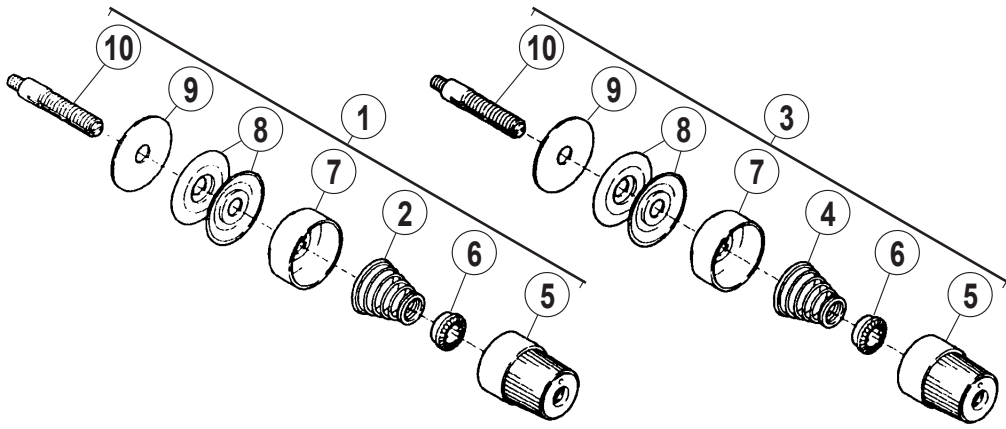

### 専用部品 (3)

### SPECIFIC PARTS(3)

REF.NO.	PART NO.	部品名称	DESCRIPTION	QT.
1	210529A9T0	糸調子 (組)	TENSION SPRING ASSY.	1
2	201086B0	円錐バネ	SPRING	1
3	210531-9T0	糸調子 (組)	TENSION SPRING ASSY.	2
4	21010680	円錐バネ (弱)	SPRING (LIGHT)	1
5	263543-TA0	ツマミ	KNOB	1
6	2084480	ラチェット	RATCHET	1
7	263544-TA0	受皿	SPRING SHIELD	1
8	2103190	調子皿	DISC	2
9	2084490	フェルト	FELT	1
10	005082A0	調子棒 /C5	SCREW STUD	1
11	275015B0	ブラケット	BRACKET	1
12	2750070	糸道	THREAD GUIDE	1
13	2750200	糸繰り	THREAD TAKE-UP	1
14	2750450	糸道	THREAD GUIDE	1
15	0070070	平小ネジ /M3X3	SCREW	1
16	275531-910	針冷却器	NEEDLE COOLER	1
17	2756140	フェルト	FELT	1

裾引き(Blindstitch hemming)  
EXT5105-12

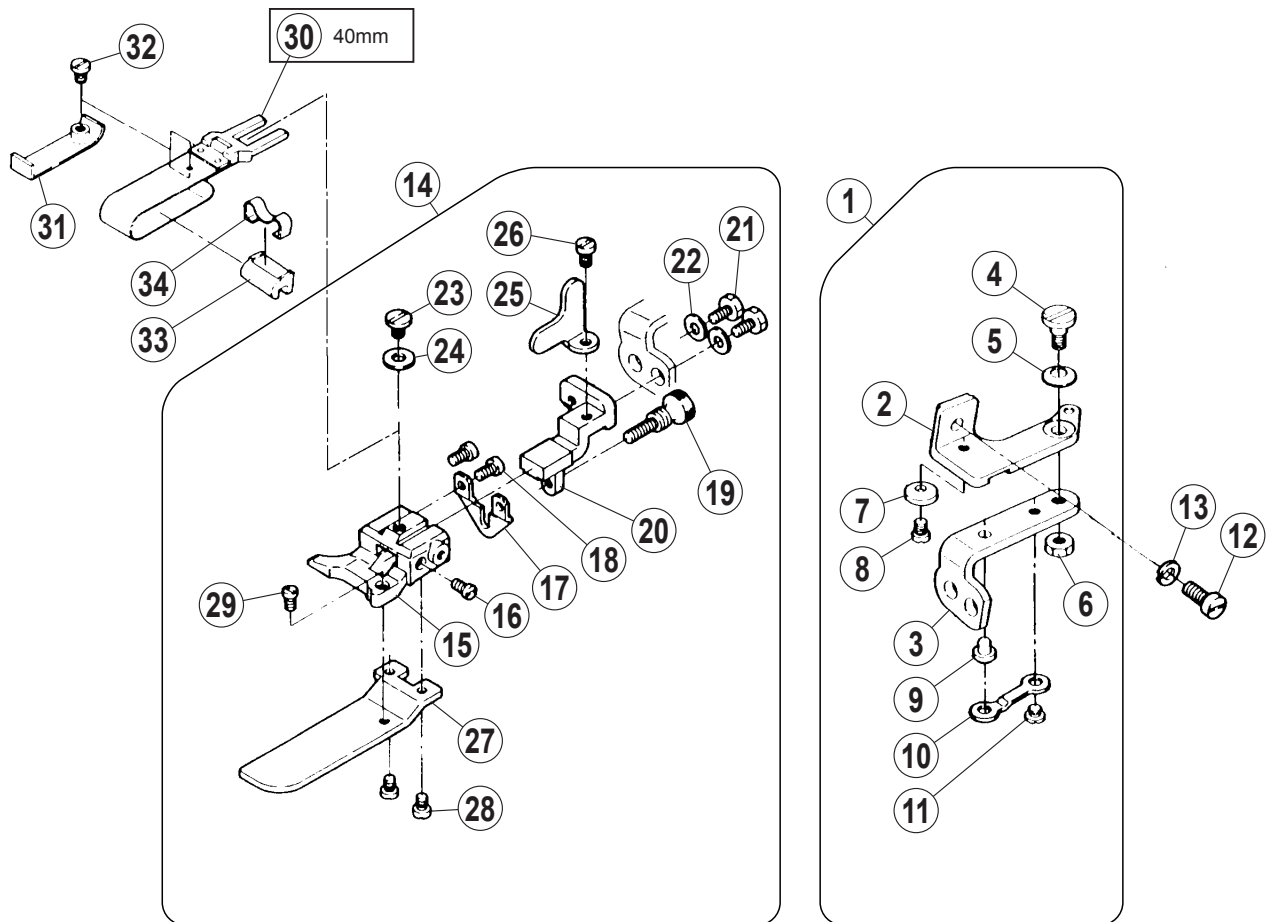



## 裾引き用アタッチメント

## ATTACHMENT FOR BLINDSTITCH HEMMING

REF.NO.	PART NO.	部品名称	DESCRIPTION	QT.
1	2106850	ブラケット (組)	BRACKET ASSY.	1
2	2106800	ブラケット	BRACKET	1
3	2106810	ヒンジ	HINGE	1
4	0051840	段ネジ /C5	SCREW	1
5	2011910	皿バネ	SPRING	1
6	0030440	六角ナット /C5	NUT	1
7	2106820	座金	WASHER	1
8	0050530	平小ネジ /C4X4.8	SCREW	1
9	2106830	ピン	PIN	1
10	2106840	板バネ	FLAT SPRING	1
11	0029060	平小ネジ /C4X2.6	SCREW	1
12	0070200	平小ネジ /M4X10	SCREW	1
13	2012520	バネ座金	WASHER	1
14	210691A910	定規台 (セット)	CLOTH GUIDE ASSY.	1
15	205361A0	定規台	CLOTH GUIDE	1
16	0050570	平小ネジ /C3X5	SCREW	1
17	2106890	ブラケット	BRACKET	1
18	0051570	平小ネジ /C3X4.5	SCREW	2
19	0024300	段ネジ /C3	SCREW	1
20	2106900	ブラケット	BRACKET	1
21	0050880	六角ボルト /C4X7.5	BOLT	2
22	1670660	座金	WASHER	2
23	0029050	平小ネジ /C5X4.5	SCREW	1
24	1371420	座金	WASHER	1
25	2106920	ストッパ	STOPPER	1
26	0012060	平小ネジ /C4X5.3	SCREW	1
27	2130950	補助板	AUXILIARY PLATE	1
28	0012290	平小ネジ /C3X4.5	SCREW	2
29	0050570	平小ネジ /C3X5	SCREW	1
30	201211C910	案内 (組) (40mm)	GUIDE ASSY. (40mm)	1
31	2058350	定規	GUIDE	1
32	0052990	平小ネジ /C3X2.6	SCREW	1
33	303312A0	ストッパ	STOPPER	1
34	3033130	クランプ	CLAMP	1

マシン形式 MACHINE TYPE /SPEC	ゲージ		針板 NEEDLE PLATE	主送り歯 (組)		主送り歯本体 MAIN FEED DOG	補助送り歯 AUX. FEED DOG	差動送り歯 DIFF. FEED DOG	上送り歯 TOP FEED DOG	押工 (組)	上ルーパー UPPER LOOPER	下ルーパー LOWER LOOPER	
	GAUGE NG	SW		MAIN FEED DOG ASSY.	277408-16F0								277403-16F0
EXT5104-02/233N	-	3	213110-300	277408-16F0		(277403-16F0)	(213103-160)	277404-16F0	2773440	277286A300	277062A0 #15	2770600	
		4	213110-400							277286A400			
		5	213110-500							277286A500			
		3	213112-300	277408-16F0		(277403-16F0)	(213103-160)	277404-16F0	2773440	277287A300	277062B0 #18	2770010	
		4	213112-400							277287A400			
EXT5104-04/433	-	5	213112-500							277287A500			
		3	213111-300	277409-16F0		(277403-16F0)	(213117-160)	277404-16F0	2773440	277286A300	2770630 #19	2770600	
		4	213111-400							277286A400			
EXT5104-04/433N	-	5	213111-500							277286A500			
		3	213110-300	277408-16F0		(277403-16F0)	(213103-160)	277404-16F0	2773440	277286A300	2770630 #19	2770600	
		4	213110-400							277286A400			

マシン形式 MACHINE TYPE /SPEC	ゲージ		上メス UPPER KNIFE	下メス LOWER KNIFE	針受		針留 NEEDLE HOLDER	針 NEEDLE	
	GAUGE NG	SW			前 FRONT	後 REAR			
EXT5104-02/233N	-	3	201121A0	213108A0	2770610	2770610	179630-920	DCX27 #9	
		4		2131080					
		5							
		3	201121A0	2131080	2770610	2770610	179630-920	DCX27 #9	
		4							
EXT5104-04/433	-	5	201121A0	213108A0	2770610	2770610	179630-920	DCX27 #11	
		3		2131080					
		4							
EXT5104-04/433N	-	5	201121A0	213108A0	2770610	2770610	179630-920	DCX27 #11	
		3		2131080					
		4							

マシン形式 MACHINE TYPE /SPEC	ゲージ		針板 NEEDLE PLATE	主送り歯 (組) MAIN FEED DOG ASSY.	主送り歯本体 MAIN FEED DOG	補助送り歯 AUX. FEED DOG	差動送り歯 DIFF. FEED DOG	上送り歯 TOP FEED DOG	押工 PRESSER FOOT	上ルーパー	下ルーパー
	GAUGE NG	SW								UPPER LOOPER	LOWER LOOPER
EXT5114-04/433	2	3	213113-300	277409-16F0	(277403-16F0)	(213117-160)	277404-16F0	2773440	277287A300	2770630 #19	2770600
		4	213113-400								
		5	213113-500								
EXT5114-04/433N	2	3	213112-300	277408-16F0	(277403-16F0)	(213103-160)	277404-16F0	2773440	277287A300	2770630 #19	2770600
		4	213112-400								
		5	213112-500								
EXT5105-12/223N	-	4	213100-400	277407-16F1	(277401-16F0)	(213103-160)	277402-16F0	2773580	277181-400	2770620 #15	2770600
EXT5104T-02/233N	-	3	277588-300	277408-16F0	(277403-16F0)	(213103-160)	277404-16F0	2773440	278011-300	2770200 #21	2770210

マシン形式 MACHINE TYPE /SPEC	ゲージ		上メス UPPER KNIFE	下メス LOWER KNIFE	針受		針留 NEEDLE HOLDER	針 NEEDLE
	GAUGE NG	SW			前 FRONT	後 REAR		
EXT5114-04/433	2	3	201121A0	2131080	2131070	2770610	277022-920	DCX27 #11
		4						
		5						
EXT5114-04/433N	2	3	201121A0	2131080	2131070	2770610	277022-920	DCX27 #11
		4						
		5						
EXT5105-12/223N	-	4	201121A0	2131080	2131070	2770610	179630-920	DCX27 #9
EXT5104T-02/233N	-	3	201121A0	213108A0	2131070	2770610	179630-920	DCX27 #9

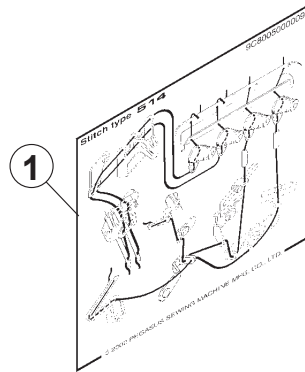

REF.NO.	部番 PART NO.	適用機種 APPLICABLE MACHINE
1	9A01150	EXT5104-02, 04 EXT5105-12
1	9A01160	EXT5114-03, 04

# インデックス

# INDEX

PART.NO.	PAGE	REF.NO.	PART.NO.	PAGE	REF.NO.	PART.NO.	PAGE	REF.NO.	PART.NO.	PAGE	REF.NO.	PART.NO.	PAGE	REF.NO.
0012060	23	26	2016290	5	15	2740400	13	16						
0012290	23	28	2021760	3	16	2740410	13	14						
0024300	23	19	2021760	11	4	274042-920	13	3						
0029050	23	23	2021760	15	16	274043A0	13	2						
0029060	23	11	2021760	19	17	2740440	13	1						
0030440	23	6	2025770	5	10	274045-910	13	6						
0045000	7	20	2041850	15	3	274048-910	13	9						
0045010	13	4	205361A0	23	15	2740510	17	3						
0045140	5	4	2058350	23	31	2740510	17	12						
0045140	5	28	2073580	3	17	2740510	17	21						
0045210	7	6	2073580	5	24	2740510	19	8						
0045310	13	8	2082350	3	37	2740540	13	10						
0045330	3	12	2082350	5	9	2740550	13	5						
0045330	5	7	2082350	5	13	2741060	17	5						
0045330	5	12	2084480	21	6	2741060	17	14						
0045330	5	22	2084490	21	9	2741060	17	23						
0045330	11	13	21010680	21	4	2741060	19	10						
0045340	3	36	2103190	21	8	274517B910	15	18						
0045340	7	2	2103200	15	10	2745290	15	13						
0045430	3	30	210529A9T0	21	1	2745300	15	14						
0045430	3	32	210531-9T0	21	3	2745490	15	9						
0045430	5	18	2106800	23	2	2745500	15	6						
0045430	5	20	2106810	23	3	274551A910	15	1						
0045430	15	5	2106820	23	7	274552A910	15	2						
0045430	15	20	2106830	23	9	2745560	15	4						
0045450	11	9	2106840	23	10	2745590	15	7						
0045450	19	18	2106850	23	1	2745920	15	12						
0045540	19	3	2106890	23	17	274593B910	15	21						
0045820	11	7	2106900	23	20	2750070	21	12						
0050300	17	9	210691A910	23	14	275015B0	21	11						
0050300	17	18	2106920	23	25	2750200	21	13						
0050300	17	27	2109300	9	5	2750450	21	14						
0050530	23	8	2109300	13	11	275531-910	21	16						
0050570	23	16	2113010	7	25	2756140	21	17						
0050570	23	29	212059-B0	17	7	276501A920	5	1						
005082A0	21	10	212059-B0	17	16	276504-910	5	11						
0050880	23	21	212059-B0	17	25	2765070	5	14						
0051570	23	18	212059-B0	19	12	2765080	5	16						
0051840	23	4	2126680	17	8	2765090	5	17						
0052990	23	32	2126680	17	17	2765100	5	19						
0070070	3	23	2126680	17	26	276511-920	5	21						
0070070	21	15	213062B0	19	1	2765120	5	23						
0070090	17	6	2130950	23	27	276513-920	7	1						
0070090	17	15	213218A920	13	7	276514A0	7	3						
0070090	17	24	2330350	19	22	2765170	7	8						
0070090	19	11	2400390	3	3	2765180	7	11						
0070100	17	4	2400390	3	27	2765190	7	23						
0070100	17	13	2400420	7	21	276520-920	3	35						
0070100	17	22	2400970	15	19	2765240	7	22						
0070100	19	9	2401480	3	19	2765260	3	7						
0070130	17	2	2401480	5	26	276527A0	3	14						
0070130	17	11	2401520	15	17	276528-910	3	20						
0070130	17	20	2402830	19	4	2765310	3	29						
0070130	19	7	2402910	3	39	2765320	3	31						
0070140	3	34	2402940	3	24	2765330	3	8						
007018A0	13	12	2402960	7	5	2765340	3	1						
007018A0	15	8	2403220	7	15	2765350	3	5						
0070200	23	12	2403320	7	13	276536-920	3	11						
007024A0	5	2	2403510	5	25	276537-920	5	27						
0070260	7	12	2403680	3	15	2765380	3	13						
0070440	3	25	2403710	15	11	2765390	3	21						
0070440	7	10	2405420	3	2	2765400	3	22						
0070541	19	21	2405420	3	26	276566-920	5	3						
0070560	3	4	2405590	7	17	2765670	5	5						
0070560	3	28	263543-TA0	21	5	276572-920	5	6						
0070590	7	24	263544-TA0	21	7	2765730	7	7						
0070660	9	8	2700670	9	9	303312A0	23	33						
0070770	7	9	2700790	9	7	3033130	23	34						
0071430	9	6	2700810	9	4	3065270	19	2						
0071500	11	2	270083A9U0	9	1									
0071500	19	15	2701680	9	3									
0071540	9	10	270522C0	19	5									
0071850	11	11	271003C0	5	8									
0071920	15	15	271015-920	11	1									
0071931	13	15	2710160	11	8									
0072060	3	9	2710170	11	10									
0072070	3	10	271018C91Y0	11	5									
0072330	3	6	271023-910	11	3									
1371420	23	24	271533B910	19	19									
1670660	23	22	271542-920	19	14									
179009-050	11	6	271544-91Y0	19	13									
179130-050	19	20	2715460	19	16									
179201-050	7	19	272538A0	7	14									
179320-050	3	18	272539A0	7	18									
2005550	7	16	273001A920	11	12									
2010220	7	4	274011-910	9	2									
201086B0	21	2	2740350	3	38									
2011910	23	5	2740360	3	41									
201211C910	23	30	2740370	3	40									
2012520	23	13	2740390	13	13									





# ペガサスミシン製造株式会社

本社 〒 553-0002 大阪市福島区鷺洲 5-7-2 TEL (06)6458-4739  
FAX (06)6454-8785

PEGASUS SEWING MACHINE MFG. CO., LTD.

5-7-2, Sagisu, Fukushima-ku, Osaka 553-0002, Japan. Phone : (06)6458-4739  
Telefax: (06)6454-8785

Cat. No. 97300  February 2004

© 1996 PEGASUS SEWING MACHINE MFG. CO., LTD.

このパーツカタログに記載されている内容は、改良のため予告なく変更することがあります。

The description in this PARTS CATALOG is subject to change without prior notice.